

Carefully read the centrifuge instruction manual and the rotor instruction manual before using the rotor.

S52ST Swing rotor (Exclusive for CS-GX II series and CS-GXL series)

Max. speed 52,000 rpm
 Max. R.C.F. 276,000 × g
 Rotor nominal capacity 20ml=5.0ml × 4
 k factor 79

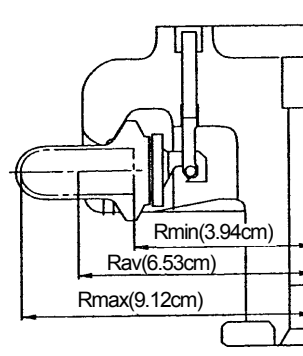

(1) Summary of tubes

Tube				Adapter		Maximum speed (rpm)	Maximum R.C.F. (× g)
Part No.	Name	Size (φ × L cm)	Net capacity (ml)	Part No.	Name		
332245A	5 PA Tube	1.3×5.2	4.9	—	—	52,000	276,000
S303273A	5 PET Tube	1.3×5.2	5.3	—	—	52,000	276,000
S301599A	3 PC Tube	1.3×5.1	3.4	—	—	52,000	276,000
S303350A	3 PA Thick-walled tube	1.3×5.1	3.4	—	—	52,000	276,000
S304296A	0.9 PC Thick-walled tube	0.8×5.0	0.9	336697A	2S5 adapter	43,000	183,000

(2) Standard accessories

Part No.	Name	Q'ty
332245A	5 PA Tube	2 (50pcs/box)
8062216	O-ring	2
474215	Cap spanner	1
S305486A	Basket stand	1
452701	Tweezers	1
Common accessories of all rotors (see Appendix)		1

(3) Centrifugal characteristics table

Speed (rpm)	Centrifugal acceleration (×g)			k factor
	Rmin (3.94cm)	Rav (6.53cm)	Rmax (9.12cm)	
10,000	4,400	7,300	10,200	2,126
15,000	9,910	16,400	23,000	945
20,000	17,600	29,200	40,900	531
25,000	27,500	45,600	63,900	340
30,000	39,600	65,700	92,000	236
35,000	54,000	89,400	125,000	174
40,000	70,500	117,000	163,000	133
45,000	89,200	148,000	207,000	105
50,000	110,000	183,000	255,000	85
52,000	119,000	197,000	276,000	79